

Optical Components

Rev. 3 [10. 2008]

OF3500B

156Mbps APD-preamplifier coaxial module with a single mode fiber

1. DESCRIPTION

OF3500B is an optical receiver module for digital transmission systems up to 156Mbps. It uses an InGaAs avalanche photodiode with a low noise preamplifier. Package style is a hermetically sealed coaxial package with a single mode fiber pigtail.

2. FEATURES

Data rate up to 156Mbps
High responsivity InGaAs-APD : 8.5A/W
Wide dynamic range
Typical sensitivity : -47.5dBm
Low noise
Small coaxial package



3. APPLICATION

SONET OC-3/SDH STM-1 applications
Long-haul transmission systems up to 156Mbps

4. OPTICAL AND ELECTRICAL CHARACTERISTICS

(Wavelength=1550nm , Tc =25°C , Vcc=3.3V, unless otherwise specified)

Parameter	Symbol	Test Conditions	Min.	Typ.	Max.	Unit
Wavelength	λ	--	1250	--	1620	nm
APD Breakdown Voltage	VBR	ID=10 μ A	40	50	70	V
Temperature Coefficient of VBR	γ	--	0.05	0.09	0.12	V/°C
APD Responsivity	RAPD	$\lambda=1.55\mu\text{m}$, M=1	0.80	0.85	--	A/W
		$\lambda=1.31\mu\text{m}$, M=1	0.75	0.85	--	
Responsivity	R	RL>500 Ω , M=10, Pin=-43dBm, Differential	160	--	--	kV/W
Bandwidth	BW	f3dB, RL>500 Ω , M=10	120	--	--	MHz
Sensitivity	Prmin	155Mbps, NRZ, BER=10 ⁻¹⁰ , PRBS2 ²³ -1, Rext=12.0dB*, M=Mopt.	--	-47.5	-46.5	dBm
Overload	Prmax	155Mbps, NRZ, BER=10 ⁻¹⁰ , PRBS2 ²³ -1, M=3	-7	-5	--	dBm
Supply Current	ICC	Pin = 0mW	--	21	26	mA
Recommended TIA Supply Voltage	VCC	--	3.1	3.3	3.5	V
Optical Return Loss	ORL	--	--	--	-27	dB

*) Extinction ratio of LD source.

OF3500B

5. ABSOLUTE MAXIMUM RATING

(Tc = 25 °C, unless otherwise specified)

Parameter	Symbol	Rating	Unit
APD Bias Voltage	VB	0 to VBR	V
TIA Supply Voltage	Vcc	4.5	V
APD Forward Current	IF	2	mA
APD Reverse Current	IR	2(cw)	mA
Operating Temperature	Tc	-40 to +85	°C
Storage Temperature	Tstg	-40 to +85	°C

6. CONNECTOR AND FIBER SPECIFICATIONS

Parameter	Specifications	Unit
Type	SM	--
Flame Rating	UL94 V-0	--
	UL1581 VW-1	--
Mode Field Diameter	10	µm
Cladding Diameter	125	µm
Jacket Diameter	900	µm
Length	1 (Min.)	m
Standard Connector	FC/PC or SC/PC	--

7. ORDERING INFORMATION

OF3500B - _ _ _ _

ex.) OF3500B-WFFC

OF3500B with a flange and FC connector.

<u>Flange</u>	<u>Connector</u>
WF	FC
NF	SC
	LC
	MU

OF3500B

8. OUTLINE DRAWING

All dimensions in millimeters

Package No. OF3500B-WF__

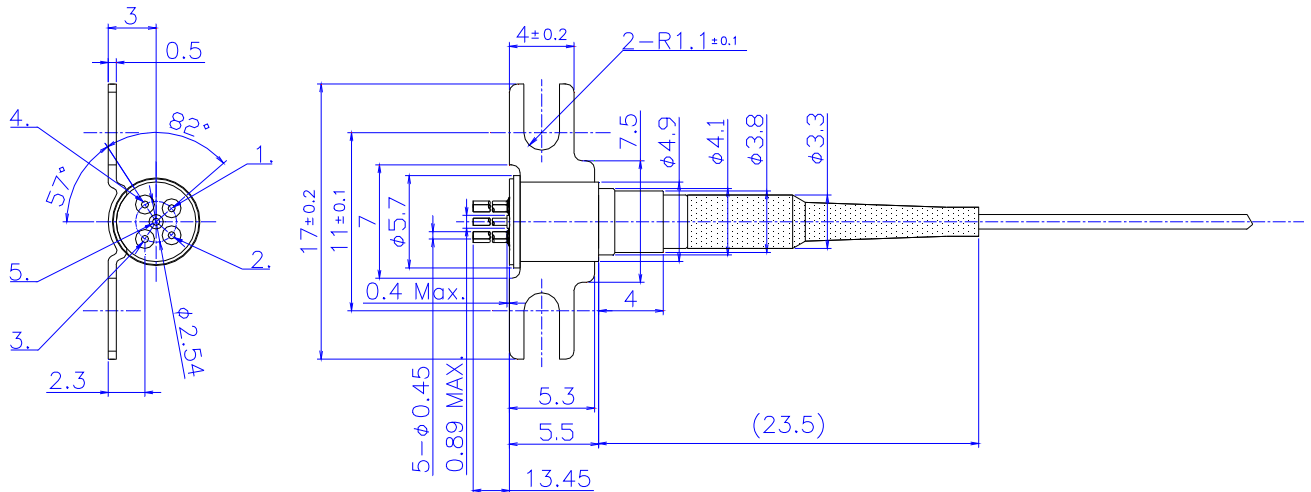

Package No. OF3500B-NF__

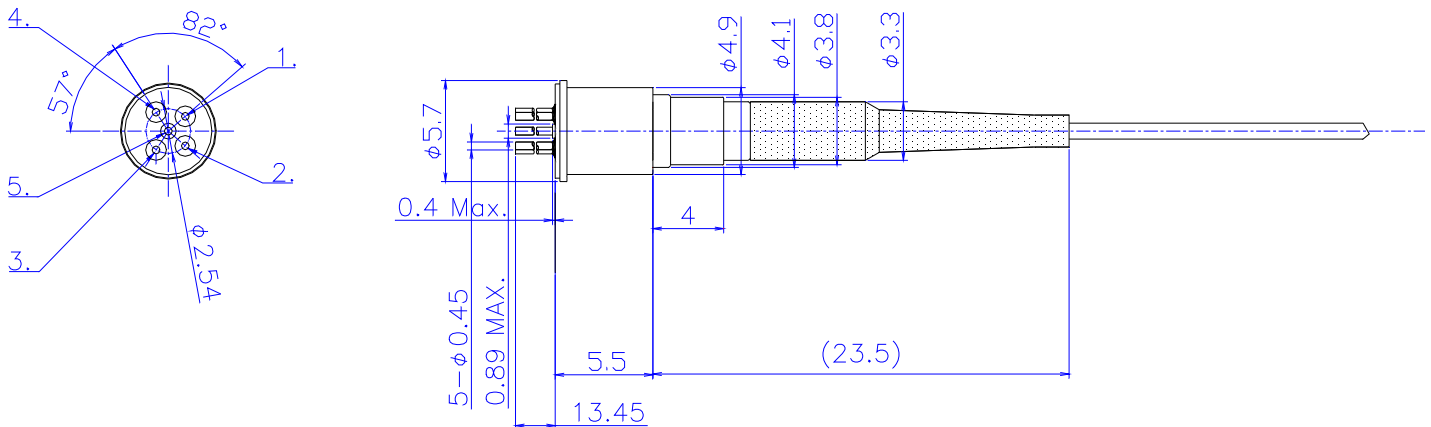

Pin Connection	
1	VCC
2	VAPD
3	VOUT-
4	VOUT+
5	GND(case)

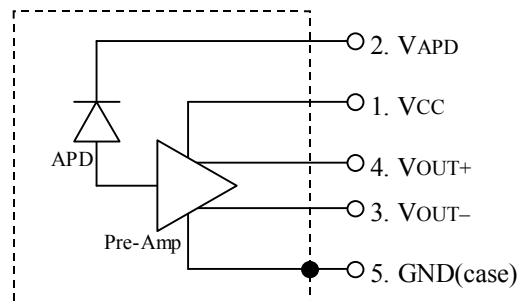

NOTE

Under the condition “ V_{APD} set, but with V_{cc} absent”, optical inputs may result in damage to the TIA. It is necessary to set V_{cc} before optical inputs to prevent such trouble.

SAFETY INFORMATION ON THIS PRODUCT

<p>Caution GaAs Product</p>	<p>The product contains gallium arsenide, GaAs. GaAs vapor and powder are hazardous to human health if inhaled, ingested or swallowed. Do not destroy or burn the product. Do not crush or chemically dissolve the product. Do not put the product in the mouth. Observe related laws and company regulations when discarding this product. The product should be excluded from general industrial waste or household garbage.</p>
<p>Caution Optical Fiber</p>	<p>A glass-fiber is attached on the product. Handle with care. When the fiber is broken or damaged, handle carefully to avoid injury from the damaged part or fragments.</p>

Notice

1. The information contained herein can change without notice owing to product and/or technical improvements. Before using the product, please make sure that the information being referred to is up-to-date.
2. The outline of action and examples for application circuits described herein have been chosen as an explanation for the standard action and performance of the product. When planning to use the product, please ensure that the external conditions are reflected in the actual circuit, assembly, and program designs.
3. When designing your product, please use our product below the specified maximum ratings and within the specified operating ranges including, but not limited to, operating voltage, power dissipation, and operating temperature.
4. OKI SEMICONDUCTOR assumes no responsibility or liability whatsoever for any failure or unusual or unexpected operation resulting from misuse, neglect, improper installation, repair, alteration or accident, improper handling, or unusual physical or electrical stress including, but not limited to, exposure to parameters beyond the specified maximum ratings or operation outside the specified operating range.
5. Neither indemnity against nor license of a third party's industrial and intellectual property right, etc. is granted by us in connection with the use of the product and/or the information and drawings contained herein. No responsibility is assumed by us for any infringement of a third party's right which may result from the use thereof.
6. The products listed in this document are intended for use in general electronics equipment for commercial applications (e.g., office automation, communication equipment, measurement equipment, consumer electronics, etc.). These products are not authorized for use in any system or application that requires special or enhanced quality and reliability characteristics nor in any system or application where the failure of such system or application may result in the loss or damage of property, or death or injury to humans. Such applications include, but are not limited to, traffic and automotive equipment, safety devices, aerospace equipment, nuclear power control, medical equipment, and life-support systems.
7. Certain products in this document may need government approval before they can be exported to particular countries. The purchaser assumes the responsibility of determining the legality of export of these products and will take appropriate and necessary steps at their own expense for these.
8. No part of the contents contained herein may be reprinted or reproduced without our prior permission.

Copyright 2008 OKI SEMICONDUCTOR CO., LTD.